

THE 2021-2025 GIRLS 5 PIECE IAPS CHAMPIONSHIPS RULES

This document is the property of IAPS. All rights reserved. This publication may not be reproduced, stored in a retrieval system, or transmitted, in any form by any means, electronic, mechanical, photocopying, recording or otherwise, without prior permission from IAPS. Please note that the rules are similar to those set by I.S.G.A. but may differ very slightly in places. Please ensure coaches read all parts, especially those highlighted in yellow.

CONTENTS

1	GENERAL	1
	COMPETITION AGE GROUPS	1
	2	
2	GENERAL COMPETITION RULES	2
	GENERAL COMPETITION DEDUCTIONS	3
3	GENERAL VAULT NOTES	3
4	SET VAULT	4
	SET VAULT UNDER 9, 10 & 11	4
	DEDUCTIONS FOR SET VAULT UNDER 9, 10 & 11	4
	SET VAULT UNDER 13	5
	DEDUCTIONS FOR SET VAULT UNDER 13	5
5	VOLUNTARY VAULT	6
	DEDUCTIONS FOR VOLUNTARY VAULT	7
6	SET FLOOR	8
	DEDUCTIONS AND NOTES FOR SET FLOOR	8
	TABLE: Under 9, 10 & 11 SET FLOOR	10
	TABLE: Under 13SET FLOOR	11
7	VOLUNTARY FLOOR	12
	GENERAL	12
	MUSIC	12
	PROGRAMME ORDER	12
	CONTENT	12
	TUMBLE RUN	12
	BONUSES	13
	DEDUCTIONS FOR VOLUNTARY FLOOR	13
	EVALUATION OF MARKS	13
	COMPOSITION	14
8	FLOOR CODE FOR IAPS. 5 PIECE	17
9	BALANCE, STRENGTH AND FLEXIBILITY ELEMENTS FOR IAPS. 5 PIECE	18

1 GENERAL

COMPETITION AGE GROUPS

Competitions shall be held in the following age groups:

- a) An under 9 competition: Under 9 on 1st September of current academic year *
- b) An under 10 competition: Under 10 on 1st September of current academic year *
- c) An under 11 competition: Under 11 on 1st September of current academic year *
- d) An under 13 competition: 11 or 12 years on 1st September of current academic year *
- e) *i.e. midnight on 31st August.

Pupils who are being taught in classes lower or higher than their chronological age at their school for any reason, must compete in their correct age group as shown above.

TEAMS

- a) A team may consist of 4, 5 or 6 gymnasts, from the same school. Where 6 gymnasts make up a team only 5 can perform on each apparatus with the top 4 scores on each discipline counting. Only 4 gymnasts may perform in the group routine. Girls in the Under 9 age group have no lower limit. It is possible to make up a team with up to two girls who are under age in the U10, and U11 age groups only. Very Small Schools may appeal in writing to the I.S.G.A. Chairman if they wish to include more than two girls competing out of age. Girls competing in the Under 13 age group must be 11 or 12 years on 1st September that academic year. Girls may only compete in one age group per academic year in the 5 Piece Championships.
- b) Girls may not compete in the 5 Piece and the 2 Piece Championships in the same academic year. The scores will be added together to produce an Individual and a Team score.
- c) No school may enter more than the allotted six gymnasts.
- d) As this is a national competition 'B' teams are not eligible.
- e) A school may not enter an individual
- f) Once a team has started its first discipline no reserve may take part. The team still has four scoring gymnasts.

COMPETITION FORMAT - FOR ALL AGE GROUPS

- Each team will perform the following:
1. Set Vault – 5 gymnasts
 2. Voluntary Vault – 5 gymnasts
 3. Set Floor – 5 gymnasts
 4. Voluntary Floor (to music) – 5 gymnasts

At this competition there is an option to also compete the group but it is a stand-alone competition.

5. Group Routine – performed by 4 of the team members (to music).

HOST SCHOOLS

Host schools must consult and agree with the Competition Secretary at least one month before a competition, **if possible**, with the following information:

- a. What type of floor will be provided i.e. Sprung or unsprung.
- b. What the exact measurements will be of the voluntary floor and group floor area.
- c. If the Velcro strips will run from front to back or side to side on the group floor area.
- d. The exact height, as near as possible to the minimum height prescribed, that the voluntary vaults and the set vaults will be for each age group. Measurements taken vertically from the floor to the vault top in a straight line.
- e. What the length of the run-up, within the customary parameters, will be for each vault.

SAFETY

For safety reasons schools should prepare their gymnasts beforehand to compete on a sprung floor area if necessary, as a number of host schools now provide them for the various competitions.

DISCLAIMER

See IAPS disclaimer

2 GENERAL COMPETITION RULES

1. The team should be uniformly dressed, in matching leotards. Deduction 0.1 per gymnast, per apparatus. All gymnasts may or may not wear matching gymnastics shorts over their leotards in the individual disciplines. In the group routine all four gymnasts must be dressed alike i.e. none of them or all of them wearing shorts. **Deduction 0.3.**
2. Gymnasts should not pull down their clothing e.g. leotard whilst being judged. Deduction 0.1. No deduction if leotard becomes indecent mid-routine. Underwear (including sports bras) if worn, should not show. Deduction 0.1. Coaches must ensure that their gymnast's leotards fit correctly to preserve modesty. Deduction 0.3 from gymnast's final score.
3. Bandages and supports are allowed but should be skin coloured. Deduction 0.1.
4. Leggings for religious reasons are allowed but must be black and worn over their leotard. String bracelets for religious reasons must be covered by skin coloured tape or a matching sweat band. Deduction 0.1.
5. Hair should be tied back neatly. Deduction for untidy hair 0.1. No jewellery in any form, including small ear studs. Deduction 0.1. No long nails or nail varnish. Deduction 0.1. If ear studs are not able to be removed, they must be covered with skin coloured tape. Deduction 0.1.
6. All teachers and coaches are required to wear professional attire suitable for a national competition. No long, coloured nails or jewellery of any type, with the exception of a plain wedding ring. Hair should be off the face and long hair tied back. Watches, if worn should be covered by a sweat band or similar. The coach may receive a deduction of up to 0.3 which will be deducted from the final score of each of the coach's teams.

7. Teams must line up before the judging panel, at the start and end of each discipline. Group routine teams must line up in front of the judging panel before competing, as in other disciplines.
8. Each gymnast must present to the judges at the start and finish of her individual floors and vaults. Group: An individual gymnast or all four may present at the start or finish of the routine.
9. Gymnasts may perform in any order on the Set/Voluntary Vault and Set Floor but must compete in programme order for the Voluntary Floor. Deduction 1.0. The gymnast's number must be shown or given to the judge before competing.
10. Girls are NOT allowed to remove any part of their leotards in public. This has been noted in particular by both male spectators and judges over the past years and is both an embarrassment and a safeguarding issue. The gymnast and her coach may have sanctions brought against them. Please see 'Catch all' rule No. 16 below.
11. The gymnast performs her Set Floor and Voluntary Floor once only and has two attempts at both the Set Vault and the Voluntary Vault, unless in the judge's opinion there has been outside interference. Gymnasts who exit from floor routines part-way through will not be permitted to start again.
12. There will be a timed warm-up of at least 3 minutes per school on the voluntary floor and set floor. The older age group team always warm up for the first 3 minutes. The older age group will also compete first unless they have fewer than 5 gymnasts, in which case the team with the most gymnasts will warm up first and compete first. There will also be a timed warm-up of at least 3 minutes for each school on each vault discipline, with the voluntary vault team warming up first and competing first if the run-up is shared. Group Routine teams have a 5 minute warm-up before lining up in front of the judging panel and then marching on to perform.
13. If a school pulls out of a competition, after the competition draw has been published, without good reason, the entry fee for each team withdrawn will be forfeited. If a school does not return a trophy in time or it is damaged or not engraved, a £50 fine will be imposed on that school. That school will also be responsible for all costs involved in getting that trophy to the new winning school shortly after the competition. If a trophy is lost or damaged a replacement must be paid for.
14. The judge's decision will be final and no video evidence will be considered under any circumstances.
15. No person may use any apparatus without a suitably qualified coach present. Teachers and coaches are responsible for their gymnasts' safety at all times.
16. 'Catch all' rule. This is to cover a circumstance that is not in the IAPS. rules. It means that if there is a problem which is brought to the Technical Director or the Head Judge that is not specified in the rules but arises during a competition, the sanction would be up to 0.5 deducted from where appropriate. This will be at the discretion of the Head Judge and/or the Technical Director. An explanation will be given to the coach.

NOTES TO COACHES: As teams only have a 3 minute warm-up before being judged and the mats are limited (i.e. 5 gymnasts on a 12 x 2 metre set floor strip), teachers are advised to prepare this warm-up time for set and voluntary floor in advance during training, to ensure maximum benefit to the pupils at the competition. Likewise on the vault, putting gymnasts together in springboard distance order and factoring in the time needed to change the vault heights, if desired, during the 3 minute warm-up. If time is taken to practise these specific short warm-up periods at school, gymnasts will feel more prepared for the competition.

GENERAL COMPETITION DEDUCTIONS

General deductions	
Teams not uniformly dressed 0.1 per gymnast, per apparatus.	Jewellery of any form 0.1
Group routine: None or all of the girls wearing shorts 0.3	String bracelets not covered 0.1
Visible underwear 0.1	Long nails or coloured nail varnish 0.1
Indecent leotards 0.3 from gymnast's final score.	Failure to present 0.1 each time
Bandages or supports not skin coloured 0.1	'Catch all' rule up to 0.5
Coach not properly attired 0.3 from the team's total.	Untidy hair 0.1
Clothing pulled down 0.1 each time. No deduction if leotard becomes indecent mid-routine.	

3 GENERAL VAULT NOTES

1. If a gymnast vaults before receiving the judge's signal, the vault is void.
2. A coach should step in if needed for safety reasons but must understand that it will void the vault.
3. A gymnast is allowed ONE 'run out' per vault, provided that she has not touched the apparatus. The SECOND attempt will be judged. If any of the apparatus is touched, the vault is deemed to be taken.
4. Schools may NOT bring their own springboard, and may not move any springboard from a piece of apparatus.
5. The gymnast may have 2 attempts at the vault and the higher score counts.
6. Each gymnast must present to the judges at the start and at the finish of each vault. Deduction 0.1 each time.
7. As is common practice in schools' gymnastics, vaulting apparatus cannot be chained to the floor.
8. All Vault deductions will be judged as: Small = 0.1, Medium = 0.3, Large = 0.5, Extra Large = 0.8 or Major = 1.0.
9. See also General Competition Deductions No. 2.1 above.

SET VAULT UNDER 9, 10 & 11

HANDSPRING FLATBACK - ONTO A PLATFORM WITH SAFETY MATS

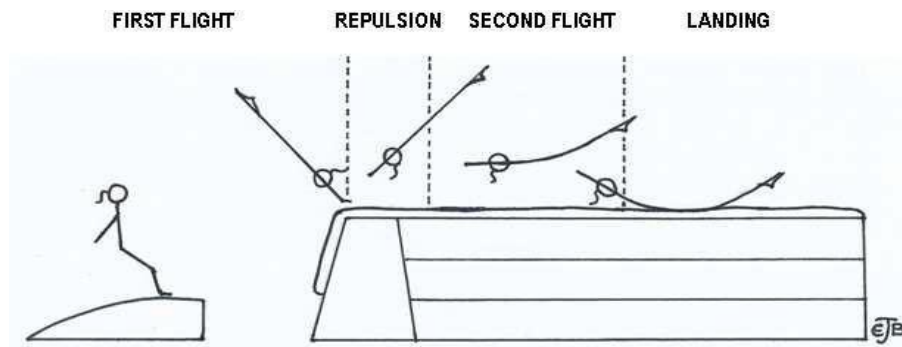

ARTIST'S IMPRESSION

- The Set Vault is marked out of 10.00.
- A vault will be used in front of the safety mats as shown in the diagram.
- The vault shall be covered with an agility mat to avoid a gap between vault and safety mats.
- The maximum combined height of the total vault plus any agility mat shall be as close to the correct height as possible.
- An arm swing must be shown during the hurdle step and the arms should be down and slightly behind the body when feet make contact with the springboard. Deduction 0.3.
- Hands must be placed on the vaulting box area and not further along on the landing mat. Deduction 0.5.
- LANDING SHAPE: A shallow dish, heels, head and arms off the mat, arms next to ears, as open as possible. LANDING TENSION: Looking at the tightness of the position and holding it for 3 seconds.
- Heights are approximate as the agility mat might alter the exact heights.
- See Deductions for Set Vault No. 4.2 below and General Vault Notes No. 3 on page 3.
- MAXIMUM HEIGHT OF VAULT:**
Under 9: 70 – 75cm **Under 10 and Under 11: 85 – 90cm**

DEDUCTIONS FOR SET VAULT UNDER 9, 10 & 11

FIRST FLIGHT	REPULSION	SECOND FLIGHT	LANDING – DISH SHAPE
Lack of arm swing 0.3	Shoulder angle 0.1 - 0.5	Insufficient height 0.1 - 0.8	Shallow dish not shown 0.1 - 0.5
Hip angle 0.1 - 0.5	Staggered hand position 0.1- 0.3	Insufficient length 0.1 - 0.5	Arch in back 0.1 - 0.3
Arched body 0.1 - 0.3	Walking on hands 0.1 per step	Insufficient stretch 0.1 - 0.5	Arms not off mat 0.1
Insufficient stretch 0.1-0.5	Double bounce on hands 0.5	Arms not by ears 0.1 - 0.3	Head not off mat 0.1
Only 1 foot take off 0.1	Hands not placed on vaulting box area 0.5		Feet not off mat 0.1
	Arms not by ears 0.1 - 0.3		Arms not by ears 0.1 - 0.3
	Failure to pass through vertical 0.1		Hands and feet not in alignment 0.1
	Head touching vault 1.0		Dish not held for 3 secs. 0.1 - 0.3
	Too long on apparatus 0.1 - 0.5		Falling off the mat 1.0

THESE DEDUCTIONS MAY BE TAKEN FROM ANY OF THE ABOVE PHASES:

Bent arms 0.1 - 0.8 – not to be taken in addition to 1.0 for head touching.

Bent legs 0.1 - 0.5

Leg, knee or feet separation 0.1 - 0.3

Deviation from straight line 0.1 - 0.5

Flexed feet 0.1

Poor body posture 0.1 - 0.3

Poor body tension 0.1 - 0.5

Dynamics 0.1 - 0.3

Support from coach any time during the vault = Void vault.

ALL VAULT DEDUCTIONS ARE JUDGED AS: SMALL = 0.1, MEDIUM = 0.3, LARGE = 0.5, EXTRA LARGE = 0.8 or MAJOR = 1.0**i.e. 0.1 – 0.3 = 0.1 or 0.3****0.1 – 0.5 = 0.1 or 0.3 or 0.5. 0.1 – 0.8 = 0.1 or 0.3 or 0.5 or 0.8**

SET VAULT UNDER 13

HANDSPRING TO REBOUND JUMP - ONTO A PLATFORM OF SAFETY MATS

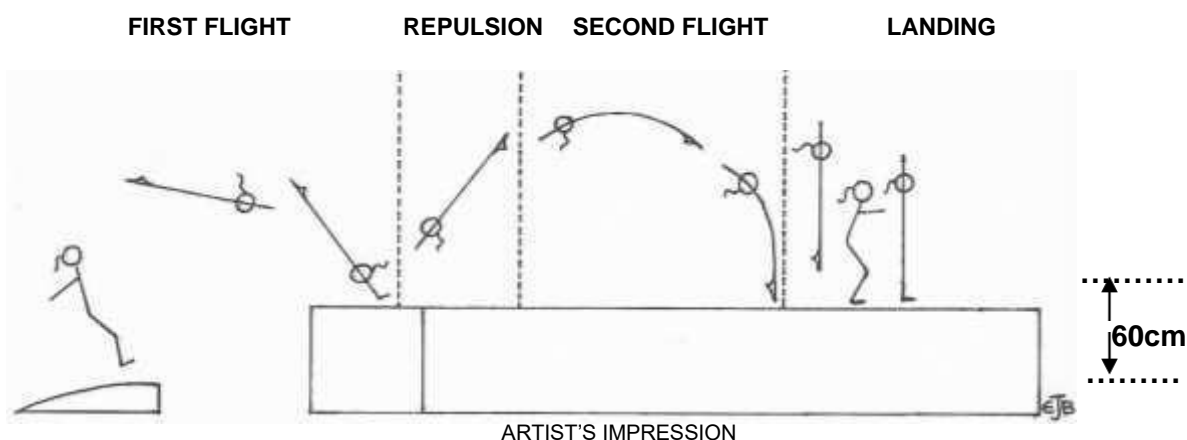

- a) The Set Vault is marked out of 10.00.
- b) The run up will be a maximum of 12m for all 3 age groups.
- c) The landing platform is to be 60cm high for all 3 age groups.
- d) A block will be placed in front of the landing platform.
- e) A sturdy mat may be placed on top of the safety mats if necessary.
- f) An arm swing must be shown during the hurdle step and the arms should be down and slightly behind the body when feet make contact with the springboard. Deduction 0.3 if not shown.
- g) Hands may be placed anywhere on the block or landing area without a deduction but this may result in a deduction for lack of repulsion.
- h) A rebound jump should be shown on the landing with arms by the ears. After the rebound jump the arms come down in front and to side to steady the landing shape before stretching up in finished position.
- i) Arms remain by the ears throughout the vault except for take-off and landing.

DEDUCTIONS FOR SET VAULT UNDER 13

FIRST FLIGHT	REPULSION	SECOND FLIGHT	LANDING
Lack of arm swing 0.3	Shoulder angle 0.1 - 0.5	Insufficient height 0.1 - 0.8	Extra arm swing 0.1
Hip angle 0.1 - 0.5	Staggered hand position 0.1- 0.3	Insufficient length 0.1 - 0.5	Lack of balance 0.1-0.3
Arched body 0.1 - 0.3	Walking on hands 0.1 per step	Insufficient stretch 0.1 - 0.5	Extra step/hop 0.1 each time
Insufficient stretch 0.1-0.5	Double bounce on hands 0.5	Arms not by ears 0.1 - 0.3	Large step (1m) or jump 0.3
Only 1 foot take off 0.1	Arms not by ears 0.1 - 0.3	Bridging to stand 0.1-0.3	Deep squat 0.5
	Failure to pass through vertical 0.1		Touch of mat with hands 0.3
	Head touching vault 1.0		Support on mat 1 or 2 hands 0.5
	Too long on apparatus 0.1 - 0.5		Fall 1.0
	Arched back 0.1-0.3		Arms not by ears in jump 0.1-0.3
			Arms not brought down in front 0.1
			No rebound jump 0.3
			No stretched finished position 0.1

THESE DEDUCTIONS MAY BE TAKEN FROM ANY OF THE ABOVE PHASES:

Bent arms 0.1 – 0.8 - not to be taken in addition to 1.0 for head touching.

Bent legs 0.1 – 0.5

Leg, knee or feet separation 0.1 – 0.3

Deviation from straight line 0.1 – 0.5

Flexed feet 0.1

Poor body posture 0.1 – 0.3

Poor body tension 0.1 – 0.5

Dynamics 0.1 – 0.3

Support from coach any time during the vault = Void vault.

ALL VAULT DEDUCTIONS ARE JUDGED AS: SMALL = 0.1, MEDIUM = 0.3, LARGE = 0.5, EXTRA LARGE = 0.8 or MAJOR = 1.0

i.e. 0.1 – 0.3 = 0.1 or 0.3

0.1 – 0.5 = 0.1 or 0.3 or 0.5

0.1 – 0.8 = 0.1 or 0.3 or 0.5 or 0.8

5 VOLUNTARY VAULT

- a) A vaulting horse will be used widthways only.
- b) Two vaults to be performed from the list below. Each vault has a different tariff. The vaults may be the same or different. Coaches may request the gymnast's first vault score, before the second vault is taken. The higher score will count.
- c) Only the vaults indicated below may be performed. Any other vault will be a void vault.
- d) Judges will add up any deductions made and then take this figure away from the tariff of the vault i.e. in a straddle vault the deductions would be deducted from 9.00 to give a final score.
- e) Vaults which do not actually go up/down to the correct height will be set at the lower height. Coaches have the choice to raise the vault to a higher setting if they wish.
- f) Vault landing deductions, other than an actual fall will be up to a maximum of 0.8.
- g) A fall on landing will be a deduction of 1.0.
- h) Half-on half-off vault. The half off phase of this vault may turn either way.
- i) Below are the minimum vault heights. Gymnasts may vault higher if they choose.
- j) See also Deductions for Voluntary Vault

VAULTS	TARIFF
Squat on, immediate straight jump off from squat position.	7.00
Squat through vault.	9.00
Straddle vault.	9.00
Handspring vault.	9.50
Half on half off vault.	10.00
Yamashita vault.	10.00

HEIGHT OF VAULT (as near as possible)	
Under 9	90 cm
Under 10	90 cm
Under 11	100 cm
Under 13	110 cm

DEDUCTIONS FOR VOLUNTARY VAULT

FIRST FLIGHT	REPULSION	SECOND FLIGHT	LANDING – ALL VAULTS
SQUAT ON and IMMEDIATE STRAIGHT JUMP OFF			Extra step or hop 0.1 each step - maximum 0.5
Insufficient stretch 0.1 – 0.8	1 knee touching vault 0.5	Insufficient height 0.1 – 0.8	Large step (1m) or jump 0.3
Insufficient layout 0.1 – 0.8	2 knees touching vault 1.0	Insufficient length 0.1 – 0.8	Deep squat 0.1 – 0.3
Only 1 foot take off 0.1	Staggered hand position 0.1 - 0.3	Insufficient extension 0.1 - 0.3	Brush of hand on mat 0.1 - 0.3
	Only 1 hand on the vault 0.5		Extra arm swing 0.1 - 0.3
	1 hand lifted before the other 0.1-0.3		Fall against apparatus 0.5
	Too long on apparatus 0.1 - 0.5		Loss of balance 0.1 - 0.3
SQUAT THROUGH VAULT			Not showing landing position 0.1 - 0.3
Insufficient stretch 0.1 - 0.8	Legs round the side 0.1 - 0.5	Insufficient height 0.1 - 0.8	Landing off the mat 0.5
Insufficient layout 0.1 - 0.8	Only 1 hand on the vault 0.5	Insufficient length 0.1 - 0.8	Failure to land feet first 1.0
Only 1 foot take off 0.1	1 hand lifted before the other 0.1-0.3	Insufficient extension 0.1 - 0.3	Under rotation-leaning back 0.1
	Staggered hand position 0.1 - 0.3		Fall 1.0
	Too long on apparatus 0.1 - 0.5		Maximum landing deductions without a fall 0.8
STRADDLE VAULT			
Insufficient stretch 0.1 - 0.8	Legs not horizontal 0.1 – 0.5	Insufficient height 0.1 - 0.8	
Insufficient layout 0.1 - 0.8	Only 1 hand on the vault 0.5	Insufficient length 0.1 - 0.8	
Only 1 foot take off 0.1	1 hand lifted before the other 0.1-0.3	Insufficient extension 0.1 - 0.3	
	Staggered hand position 0.1 - 0.3		
	Too long on apparatus 0.1 - 0.5		
HANDSPRING VAULT			
Hip angle 0.1 - 0.5	Shoulder angle 0.1 - 0.5	Insufficient height 0.1 - 0.8	
Arched body 0.1 - 0.3	Failure to pass through vertical 0.1	Insufficient length 0.1 - 0.8	
Insufficient stretch 0.1 - 0.5	Arms not by ears 0.1 - 0.3	Arms not by ears 0.1 - 0.3	
Arms not by ears 0.1 - 0.3	Staggered hand position 0.1 - 0.3	Insufficient extension 0.1 - 0.3	
Only 1 foot take off 0.1	Only 1 hand on the vault 0.5		
	1 hand lifted before the other 0.1-0.3		
	Too long on apparatus 0.1 - 0.5		
	Arched back 0.1 - 0.3		
	Head touching vault 1.0		
YAMASHITA VAULT			
Hip angle 0.1 - 0.5	Shoulder angle 0.1 - 0.5	Insufficient height 0.1 - 0.8	
Arched body 0.1 - 0.3	Failure to pass through vertical 0.1	Insufficient length 0.1 - 0.8	
Insufficient stretch 0.1 - 0.5	Arms not by ears 0.1 - 0.3	Arms not by ears 0.1 - 0.3	
Arms not by ears 0.1 - 0.3	Staggered hand position 0.1 - 0.3	Lack of pike position 0.1 - 0.5	
Only 1 foot take off 0.1	Only 1 hand on the vault 0.5	Insufficient extension 0.1 - 0.3	
	1 hand lifted before the other 0.1-0.3	Late extension 0.1 - 0.3	
	Too long on apparatus 0.1 - 0.5		
	Arched back 0.1 - 0.3		
	Head touching vault 1.0		
HALF ON HALF OFF VAULT			
Hip angle 0.1 - 0.5	Shoulder angle 0.1 - 0.5	Insufficient height 0.1 - 0.8	
Arched body 0.1 - 0.3	Failure to pass through vertical 0.1	Insufficient length 0.1 - 0.8	
Insufficient stretch 0.1 - 0.5	Arms not by ears 0.1 - 0.3	Arms not by ears 0.1 - 0.3	
Arms not by ears 0.1 - 0.3	Staggered hand position 0.1 - 0.3	Insufficient extension 0.1 - 0.3	
Incomplete turn on 0.1-0.8	Only 1 hand on the vault 0.5	Incomplete turn off 0.1 - 0.8	
Only 1 foot take off 0.1	Too long on apparatus 0.1 - 0.5		
	Arched back 0.1 - 0.3		
	Head touching vault 1.0		
THESE DEDUCTIONS MAY BE TAKEN FROM ANY OF THE ABOVE PHASES:			
Bent arms 0.1 - 0.8 – not to be taken in addition to 1.0 for head touching.			
Leg, knee or feet separation 0.1 - 0.3		Bent legs 0.1 - 0.5	
Flexed feet 0.1		Deviation from straight line 0.1 - 0.5	
Poor body tension 0.1 - 0.5		Poor body posture 0.1 - 0.3	
Support from coach on either side of the vault = Void vault		Dynamics 0.1 - 0.3	
ALL VAULT DEDUCTIONS ARE JUDGED AS: SMALL = 0.1, MEDIUM = 0.3, LARGE = 0.5, EXTRA LARGE = 0.8 or MAJOR = 1.0			
i.e. 0.1 – 0.3 = 0.1 or 0.3		0.1 – 0.5 = 0.1 or 0.3 or 0.5	
		0.1 – 0.8 = 0.1 or 0.3 or 0.5 or	

6 SET FLOOR

Set Floor for Under 9, 10 & 11

Show good upright posture with tension for 3 seconds.	
Handstand forward roll, immediate split jump.	1.4
360° spin.	1.0
Cartwheel.	1.0
¼ turn backwards on toes.	0.4
Forward horizontal leg lift and upright arabesque balance. Each for 3 seconds.	1.4
Round off, immediate rebound star jump.	1.4
Backward roll to straddle stand.	1.0
Forward roll, immediate 360° high straight jump.	<u>1.4</u>
	9.0
	Bonuses
	<u>1.0</u>
	TOTAL
	10.0

Set Floor for Under 13

Show good upright posture with tension for 3 seconds.	
540° spin.	0.8
Backward roll to front support.	0.8
180° high straight jump.	0.8
Round off, jump 180° to land on one foot, into a cartwheel ¼ turn inwards to lunge.	1.4
Upright arabesque.	0.8
Squat position then forward roll into a dish position.	0.8
Free V-sit position.	0.8
Unsupported shoulder stand immediate 360° high straight jump.	1.4
Handstand forward roll, immediate split jump.	<u>1.4</u>
	9.0
	Bonuses
	<u>1.0</u>
	TOTAL
	10.0

DEDUCTIONS AND NOTES FOR SET FLOOR

- The routine to be performed along a strip of mat approximately 2metres wide.
- There will be a deduction of 0.1 for stepping off the strip (each time).
- Gymnasts are allowed to start from either end of the strip.
- Missing elements – deduct the value of the move and elements performed in the incorrect order – deduct 0.5.
- Attempted moves will receive a deduction on execution only i.e. Handstand forward roll, falls backwards to feet or if the bonus in the backward roll is attempted and the handstand falls backwards - deduct 0.5. See notes for coaches and judge on page 9.
- There will be a deduction of 0.3 for a small prompt from coaches, gymnasts or others and a deduction of 0.5 for a large prompt. Up to a maximum total of 1.0.
- All Set Floor deductions will be judged as: Small = 0.1, Medium = 0.3, Large = 0.5 or Major = 1.0.
- A fall is a deduction of 1.0 but only when the gymnast falls over completely. A touch of the floor i.e. with a hand, foot or other body part is 0.1 or 0.3. Adjustment/loss of control when entering a balance e.g. V-sit or shoulder stand is 0.3 or 0.5.
- In a number of cases the position of the arms is specified. When not specified, the arms should be simple and in keeping with the agilities and not flamboyant and/or distracting between moves. Any extra steps, shuffles, bounces, 'flowery' arm or body movements which deviate from the text are deductible 0.1 - 0.3 each time.
- Each gymnast must present to the judges at the start and at the finish of the routine. Deduction 0.1 each time.
- See also General Competition Deductions

NOTES FOR COACHES AND JUDGES FOR BOTH SET FLOORS:

Handstand forward roll split jump:

- There is no voluntary step into the start of the handstand. From standing the leg is lifted immediately into the move. If the lifted foot touches the floor again before stepping into the lunge for the handstand, deduct 0.3.
- If the gymnast performs the handstand forward roll but omits the split jump, deduct 0.7.
- If the gymnast performs the forward roll split jump but omits the handstand, deduct 0.7.
- If the handstand falls back down to the feet, i.e. no roll deduct 0.5. The gymnast must then perform a forward roll immediate split jump. If the handstand is repeated, deduct 0.3.
- It is a move that must be linked and the forward roll is the linking factor. If there is no forward roll before the split jump then the whole value of the move is forfeited 1.4.
- The split jump is immediate and starts as the gymnast is coming out of the roll. If the gymnast finishes the roll in a standing position before starting to execute the split jump, the jump has not begun out of the roll and will therefore incur deductions. There should be only one arm movement or swing, finishing with the arms diagonally high above the head.

NOTES FOR UNDER 9, 10 & 11 SET FLOOR:

Backward Roll: The gymnast may perform a backward roll with straight legs and she may put her hands down to touch on the floor and then put them by her ears on the floor with no deduction (i.e. 2 touches in the roll). A bonus will be given for keeping the legs straight throughout but there is no bonus available for touching only once. A backward roll can be performed from standing or from a squat position. Either is acceptable. If the roll is performed from squat then the roll is on the back with hands going on the floor only once behind the head in order to achieve the push up to finish in straddle stand. Performed from standing it may be performed with hands at the side or with an upward arm swing. From here it may drop straight to sit and backward roll or the hands may be placed briefly on the floor to gain control and then be placed behind the head to push from the floor. Both are acceptable and should not be penalised in any way. It is not a fall. **Bonus 2:** The backward roll to handstand bonus must have feet together in the handstand and then lower legs to a straddle stand position.

Forward Horizontal Leg Balance: The free leg may be lifted straight into the balance position or it may be slid out in front to point the toe before lifting into the balance position. If the foot is slid out to point, the foot must not be lifted off the floor before pointing the toe, deduct 0.3.

Forward roll, immediate 360° high straight jump: The high straight jump is immediate and starts as the gymnast is coming out of the roll. If the gymnast finishes the roll in a standing position before starting to execute the 360° high straight jump, the jump has not begun out of the roll and will therefore incur deductions. If the gymnast performs the forward roll but omits the 360° high straight jump, deduct 0.7. There should be only one arm movement or swing.

NOTES FOR UNDER 13

Backward Roll to front support:

The backward roll may be performed with bent or straight legs. If legs are kept straight, the gymnast may put hands down to touch on the floor and then put them by ears on the floor with no deduction. (i.e. 2 touches in the roll). A bonus will be given for keeping the arms straight throughout but there is no bonus available for touching only once.

Round off jump 180° to land on one foot, into a cartwheel ¼ turn inwards to lunge: The arms should be by the ears on landing in the lunge. They are then pulled back to a high V position. At the same time the chest is pulled back to an upright position but the legs remain in a lunge with the front knee bent at 135° and the back leg straight. If feet are joined before the high V position with the arms is shown, deduct 0.3.

6.2 TABLE: Under 9, 10 & 11 SET FLOOR		DEDUCTIONS	BONUSES
Stand showing good upright posture with tension for 3 secs.		Deduct 0.1 for poor posture and lack of tension. Deduct 0.1 for each second not held.	
Immediately lift into, <u>handstand forward roll</u> , <u>immediate split jump</u> . The jump should start out of the roll finishing with arms diagonally high above head. There should be only one arm movement or swing from roll to jump. See notes for coaches and judges on page 9.	1.4	Deduct 0.3 if lifted toe touches floor and is lifted again before the handstand. Deduct 0.5 if the handstand falls. The roll and split jump must then be performed. Deduct 0.3 if the handstand is repeated. Deduct 0.1 – 0.3 for pause between roll and jump or jump not starting out of roll. Deduct 0.1 – 0.3 for any extra arm swing. Deduct 0.1 – 0.3 for bent legs or toes not pointed in handstand or jump. Deduct 0.1 – 0.5 for 180° split not shown in the jump. Deduct 0.1 for arms not finishing diagonally high above head.	0.1 for handstand held for 2 seconds. 0.1 for straight arm roll. 0.1 for height in jump.
Step forward into 360° spin on toes. Free leg high with toe to knee, finishing in front with foot turned out. Back foot extended with toe pointed behind on floor (pose). Arms optional in spin, but should finish diagonally high. Bonus: To gain the bonus the free leg must, after the spin, extend out horizontally in front of the gymnast and then be lowered to the floor in a controlled manner.	1.0	Deduct 0.1 – 0.5 for not completing the 360°. Deduct 0.1 if spin is reversed. Deduct 0.1 if toe is not to knee in spin. Deduct 0.1 if the spin is not on the toes. Deduct 0.1 if front foot is not turned out in finished position. Deduct 0.1 if back foot is not pointed behind on floor in a pose. Deduct 0.1 for arms not finishing diagonally high.	0.1 for extending the free leg out to horizontal in front and lowering it with control.
Join the back foot to the front, jump forwards into a hurdle step with lunge and <u>cartwheel</u> . Finish facing sideways with arms diagonally high.	1.0	Deduct 0.3 for jump forward into a hurdle step with lunge not shown. Deduct 0.1 – 0.3 for lack of extension and tension. Deduct 0.1–0.3 for deviation from straight line. Deduct 0.5 for an aerial cartwheel. Deduct 0.1 for arms not finishing diagonally high.	0.1 for flight into cartwheel.
Up on toes $\frac{1}{4}$ <u>turn backwards on toes</u> to face the way the gymnast has just come, join back foot to front foot on toes then lower the heels. Arms must remain diagonally high.	0.4	Deduct 0.1 – 0.3 for lack of control and for lowering heels too early. Deduct 0.1 for lack of extension and tension. Deduct 0.1 for arms not diagonally high throughout.	
Lower arms to shoulder height and out to the side. Slide foot forward to point the toe on the floor and then lift a straight leg into a <u>forward horizontal leg balance</u> . Hold for 3 secs. Alternatively the free leg may be lifted immediately into the balance position. Lower held leg (but do not touch the floor) and take it to the back into an <u>upright arabesque balance</u> . Hold for 3 seconds. The leg need only be raised to 45° at the back. Lower leg to join feet. See notes on page 9.	1.4	Deduct 0.3 if the foot is lifted off the floor before pointing the toe. Deduct 0.3 – 0.5 if the foot touches the floor between forward leg lift and arabesque. Deduct 0.1 – 0.5 for leg below 90° in the forward horizontal leg lift. Deduct 0.1 for leg below 45° in arabesque. Deduct 0.1 – 0.3 if arms are not out to the side, i.e. Back or above/below 10° from the horizontal. Deduct 0.1 – 0.3 for bent legs and toes not pointed. Deduct 0.1 – 0.5 for chest and head not upright in balances. Deduct 0.1 for each second not held.	0.1 for forward leg lift above 90°, held for 3 seconds.
Jump forwards into a hurdle step with lunge and <u>round off</u> , <u>immediate rebound star jump</u> with controlled landing.	1.4	Deduct 0.3 for jump forward into a hurdle step with lunge not shown. Deduct 0.1 – 0.5 for lack of repulsion in round off. Deduct 0.1 – 0.3 for lack of height and good slight dish shape in star jump. Deduct 0.1 – 0.5 for loss of control in the rebound & deviation from straight line. Deduct 0.1 – 0.3 for uncontrolled landing.	0.1 for dynamics.
<u>Backward roll</u> to finish in <u>straddle stand</u> with arms diagonally high above head. If aiming for the handstand bonus, lift the hips high and show the handstand position with feet together then lower legs to straddle stand. See notes for coaches and judges on page 9.	1.0	Deduct 0.1 – 0.5 for lack of push on hands and extension of arms to raise hips i.e. rolling over the head. Deduct 0.5 if handstand bonus is attempted but is unsuccessful. A second attempt is not permitted, deduct 0.3, but the straddle stand position must be shown. Deduct 0.1 if straddle stand position is not shown. Deduct 0.1 for lack of extension and stretch in handstand if bonus is attempted. Deduct 0.1 for arms not finishing diagonally high.	0.1 for straight legs throughout. 0.1 for lift to handstand with feet together then lower legs to straddle stand.
From feet apart, jump feet together and immediately <u>forward roll</u> , immediate 360° high straight jump starting out of the roll, to finish with a secure landing. Only one arm movement or swing allowed from roll to jump. See notes for coaches and judges on page 9.	1.4	Deduct 0.1 – 0.3 for pause between jumping the feet together and the roll. Deduct 0.1 – 0.3 for pause between the roll and jump or jump not starting out of roll. Deduct 0.1 – 0.3 for any extra arm swing. Deduct 0.1 – 0.3 for lack of height, extension and tension in jump.	0.1 for secure landing after 360° high straight jump.

Total of Content	9.0	Total of Bonuses	1.00
-------------------------	------------	-------------------------	-------------

6.3 TABLE: Under 13 SET FLOOR		DEDUCTIONS	BONUSES
Stand showing good upright posture for 3 seconds.		Deduct 0.1 for poor posture and lack of tension. Deduct 0.1 for each second not held.	
Step forward into 540° spin on toes. Free leg, high with toe to knee, finishing in front with foot turned out. Back foot extended with toe pointed behind on floor (pose). Arms optional in spin, but should finish diagonally high.	0.8	Deduct 0.1 – 0.5 for not completing the 540°. Deduct 0.1 if spin is reversed. Deduct 0.1 if toe is not to knee in spin. Deduct 0.1 if spin is not on toes. Deduct 0.1 if front foot is not turned out in finished position. Deduct 0.1 if back foot is not pointed behind on floor in a pose.	
Join the back foot to the front foot and take arms to a parallel position above head. <u>Backward roll to front support</u> . This may be performed with bent or straight legs. Hold front support position for 3 seconds.	0.8	Deduct 0.1 for hands not facing forward. Deduct 0.1 for chest not rounded. Deduct 0.1 for body not straight and head in line with body. Deduct 0.1 for hands not shoulder width apart. Deduct 0.1 for each second not held.	0.1 for straight arms throughout.
Squat in and immediate <u>180° high straight jump</u> . The jump should start from the squat position. There should be only one arm movement or swing from squat position to jump.	0.8	Deduct 0.1 – 0.3 for pause between the squat in and the jump. Deduct 0.1 – 0.3 for extra arm swing. Deduct 0.1 – 0.3 for lack of height in jump. Deduct 0.1 for lack of stretch in jump. Deduct 0.1 – 0.3 for lack of secure landing.	
Jump forwards into a hurdle step with lunge and <u>round off, straight jump 180° to land on one foot, into a cartwheel ¼ turn inwards to lunge</u> . Finish in a lunge with arms by the ears. Then pull arms back to finish in high V, with chest upright, whilst remaining in a lunge with front knee bent (135°) and back leg straight. See notes for coaches and judges on page 9.	1.4	Deduct 0.3 if jump forward into a hurdle step with lunge not shown. Deduct 0.1 – 0.3 for any pauses between the moves. Deduct 0.1 – 0.5 for lack of repulsion and rebound in round off. Deduct 0.1 – 0.3 for lack of height, stretch and tension in the 180° straight jump. Deduct 0.1 – 0.3 for lack of extension and tension in cartwheel. Deduct 0.1 – 0.5 for loss of control or deviation from straight line. Deduct 0.1 for not finishing in a lunge and 0.1 for arms not finishing diagonally high. Deduct 0.3 if feet are joined before the high V position with the arms is shown.	0.1 for dynamics. 0.1 for flight into cartwheel.
Join the back foot to the front foot and take the arms out to the side. Raise a leg to the back into an <u>upright arabesque</u> . The foot must not be pointed on the floor behind before lifting into the arabesque. The leg at the back needs to be raised to a minimum of 45°. Hold for 3 seconds.	0.8	Deduct 0.1 – 0.3 if arms not at side i.e. back or above/below 10° from horizontal. Deduct 0.1 – 0.3 for bent legs and toes not pointed. Deduct 0.1 – 0.5 if chest and head not upright. Deduct 0.3 if the foot is pointed on the floor behind before lifting. Deduct 0.1 for each second the arabesque is not held. Deduct 0.1 for leg below 45°	0.1 for leg raised to 90° at the back.
Join back foot to front foot. Show squat position with straight back and arms stretched out in front. <u>Forward roll into a dish position</u> . Arms by ears and hands and feet in alignment. Hands, shoulders and feet off the floor and back should not arch. Hold for 3 seconds.	0.8	Deduct 0.3 for squat position not shown. Deduct 0.1 for back not straight and 0.1 for arms not forward in squat position. Deduct 0.1 – 0.3 for arched back in the dish position. Deduct 0.1 – 0.3 if arms are not by the ears or hands and feet not in alignment. Deduct 0.1 for each of hands, shoulders or feet not off the floor. Deduct 0.1 for each second the dish position is not held.	
Raise legs and torso into a <u>free V-sit position</u> . Legs may be tucked while being raised or they may be kept straight for the bonus. The back and legs must be straight. The arms must be low and straight but not touching the floor or the legs. The V shape must be equilateral. Hold for 3 seconds.	0.8	Deduct 0.3 - 0.5 for adjustment or loss of control i.e. hand or foot touching the floor on raising the legs and torso into the free V-sit. Deduct 0.1 – 0.3 for back or legs not straight in the V-sit. Deduct 0.1 – 0.3 for incorrect V-shape. Deduct 0.1 for arms not straight and low. Deduct 0.1 for arms touching legs. Deduct 0.1 for each second the V-sit is not held.	0.1 for lifting legs from dish up into free- v-sit without tuck position.
Lower straight legs onto floor into long sit position. Arms optional. Roll back with straight legs into an <u>unsupported shoulder stand</u> . Arms straight on floor by hips. Hold for 3 seconds. Roll down into an immediate 360° <u>high straight jump</u> . The jump should start out of the roll. There should be only one arm movement or swing from roll to jump.	1.4	Deduct 0.1 – 0.3 for bending legs when rolling back into shoulder stand. Deduct 0.3 - 0.5 for adjustment or loss of control going into the shoulder stand. Deduct 0.1 – 0.5 for legs not vertical. Deduct 0.1 for each second not held. Deduct 0.1 – 0.3 for pause between roll and jump or jump not starting out of roll. Deduct 0.1 – 0.3 for any extra arm swing. Deduct 0.1 – 0.3 for lack of height in jump. Deduct 0.1 – 0.3 for lack of stretch and tension in jump.	0.1 for arms on floor above head in shoulder stand. 0.1 for secure landing.

<p>Handstand forward roll, immediate split jump. The jump should start out of the roll finishing with arms diagonally high above head. There should be only one arm movement or swing from roll to jump. See notes for coaches and judges on page 9.</p>	<p>1.4</p>	<p>Deduct 0.3 if lifted toe touches the floor and is lifted again before the handstand. Deduct 0.5 if the handstand falls. The roll and split jump must then be performed. Deduct 0.3 if handstand is repeated. Deduct 0.1 – 0.3 for any extra arm swing. Deduct 0.1–0.3 for pause between roll and jump or jump not starting out of roll. Deduct 0.1 – 0.5 for 180° split not shown in the jump. Deduct 0.1 – 0.3 for bent legs and toes not pointed in handstand or jump. Deduct 0.1 if arms do not finish diagonally high above head.</p>	<p>0.1 for handstand held for 2 seconds. 0.1 for straight arm roll. 0.1 for height in jump.</p>
<p style="text-align: right;">Total of Content</p>	<p>9.0</p>	<p style="text-align: right;">Total of Bonuses</p>	<p>1.00</p>

7 VOLUNTARY FLOOR

GENERAL

- a) Floor work must use the entire body and should contain acrobatic elements artistically performed, movements and linkages combining liveliness, poise, balance, variations of moves, change of pace, musical interpretation and must use the floor area, (normally 12 m x 12 m), as fully as possible.
- b) The routine must be performed to music. The music and movement must be in harmony.
- c) The duration of the routine should be between 50 – 70 secs. The routine is timed from the gymnast's first movement until her last movement. The gymnast must finish with the end of the music. Coaches or musical operator will not be allowed to stop the CD early.
- d) There will be a deduction of 0.3 for a small prompt from coaches, gymnasts or others and a deduction of 0.5 for a large prompt. Up to a maximum total of 1.0.

MUSIC

- a) Music will be played by the coach via Bluetooth device. A Bluetooth speaker will be available. Please ensure your music is downloaded to your device as wi-fi may not be good enough to bring the music from the cloud and will result in the music failing to play. The music must be instrumental and not vocal i.e. no words but it may have voice as an instrument. It may have up to an 8 beat introduction.
- b) If you wish to use CDs it is up to you to bring CDs and a suitable CD player on the day.
- c) It is forbidden to use music or any derivatives or remixes from: Andrew Lloyd Webber e.g. Variations, Cats, Phantom etc., Cirque du Soleil e.g. Alegria, Quidam, Luzia etc. or Walt Disney/Pixar e.g. Pirates of the Caribbean, Narnia or any Disney Classic. Anyone using those pieces of music will have the music turned off during the gymnast's performance and they will have to continue without music. There is now a declaration on the entry form for the School's coach to complete, saying that they are accepting liability that the floor music being used by their gymnasts is not from any of the above forbidden music.

PROGRAMME ORDER

All gymnasts must compete in programme order on the voluntary floor. Coaches should bear this in mind when listing their gymnast's names on the entry form as this will be their voluntary floor order. If a team competes out of order on the voluntary floor, the sanction is 1.00. This will be deducted from the final team score.

CONTENT

The content used to construct the floor routine, must be taken from the IAPS Code. See page 17. A routine must contain at least **ten different moves**. The ten moves may include any number of Elementary, Intermediate or Advanced moves. The value of the move may be lost unless it is performed safely and correctly. If no Intermediate moves or Advanced moves are included, then ten elementary moves must be performed. More than ten moves from the Code may be included in the routine, but no extra marks will be given. 0.3 of a mark will be deducted per move for less than ten performed.

Repeated moves will not be counted towards the Content but could receive execution deductions if not performed correctly. Where a gymnastic move is used more than once in a routine, only its first performance will be counted as one of the required moves. This includes moves used in the tumble run.

7.5 TUMBLE RUN

The routine must include a diagonal gymnastic tumble run, with a minimum of three different moves from the code (i.e. no repeated moves) and no connecting steps. The tumble run should be dynamic and it should accelerate

- a) Gymnastic moves used in the tumble run will count towards the minimum ten moves required in the routine.
- b) A straight jump half turn to land on one foot is not in the IAPS. code. It does NOT count as a move in the tumble run. It may be used as a rebound link without any 'connecting step' deductions. A round off, straight jump half turn immediate cartwheel is only 2 moves, as the jump half turn would have to land on one foot. It would require a 3rd move to meet the tumble run requirement. A straight jump half turn to land on two feet is in the I.S.G.A. code, so it is important to focus on the execution as it DOES count as a move in the tumble run, e.g. round off, straight jump half turn, forward roll.
- c) No more than one jump or leap may be included and if used it will count as one of the 10 moves.

- d) A round off, flic to two feet together followed by a second flic landing with 2 feet together counts as only 2 moves as the second flic is a repeated move. A round off, flic to 2 feet followed by a flic walkout counts as three moves.
- e) There will be a deduction of 0.5 if there is no tumble run.
- f) There will be a deduction of 0.1 for deviation from a straight line in the tumble run.
- g) **There will be a deduction of 0.1 if the tumble run is not performed diagonally.**
- h) **There will be a deduction of 0.1 if the tumble run is not dynamic and it does not accelerate.**
- i) If a move which has already been performed earlier in the routine is then repeated in the tumble run, it would not be counted and the judge would deem the tumble run invalid as it does not have the required three elements (deduction 0.5). A way to reduce the likelihood of this problem occurring would be to place the tumble run relatively early in the routine.

7.6 BONUSES

An Intermediate move is worth 0.3 and an Advanced move is worth 0.4. A gymnast is able to score no more than 1.0 worth of bonuses. This can be made up with 2 Intermediate moves (2 x 0.3 = 0.6) and 1 Advanced move = 0.4. Additional Intermediate or Advanced moves may be included but will not score any higher than the 1.0 bonus and they could receive execution deductions if not performed correctly. An Advanced move can replace an Intermediate move to score full bonus i.e. 2 Advanced moves plus 1 Intermediate move or 3 Advanced moves. The Bonus rule applies to all age groups.

7.7 DEDUCTIONS FOR VOLUNTARY FLOOR

GENERAL DEDUCTIONS	
Music with vocals, i.e. words in the music 0.5	Stopping musical recording early 0.5
No music supplied 0.5	Finishing before or after the music 0.3
Music supplied but does not play or stops and is not the fault of the audio equipment 0.1	Over time or under time 0.1
EXECUTION PENALTIES for skills from the list in the table on page 15 and dance.	
Small execution fault 0.1	Insufficient height in jumps/aerials 0.1 or 0.3
Medium execution fault 0.3	Insufficient flight in flight elements 0.1 or 0.3
Large execution fault 0.5	Insufficient tuck/pike/stretch 0.1 or 0.3
Incorrect body shape 0.1 or 0.3	Static skills not held for 3 seconds 0.1 for each second.
Bent arms 0.1 or 0.3	Balances not held for 3 seconds 0.1 for each second.
Bent legs 0.1 or 0.3	Handstand & front support not held 2 seconds 0.1 each second
Leg separation 0.1 or 0.3	Extra steps/hops on feet or hands 0.1 each time.
Lack of split 0.1 or 0.3 or 0.5	Arm swings to maintain balance 0.1 or 0.3
Feet not pointed 0.1	Posture fault on landing 0.1 or 0.3
Failure to extend from somersault 0.1	Loss of balance 0.1 or 0.3 or 0.5
Incomplete 360° spin within 45° - 0.1 or 0.3. Less than 45° the skill does not count.	Adjustment/loss of control when entering a balance e.g. V-sit, headstand, straddle lever etc. 0.3 or 0.5
Incomplete 540° or 720° spin within 45° - 0.1 or 0.3 or 0.5. Less than 45° the skill will be downgraded to a 360° or 540° spin.	Touch of the floor i.e. with a hand, foot or other body part 0.1 or 0.3 Fall – actually falling over completely 1.0
DEDUCTIONS taken throughout the routine.	
One foot outside of floor area 0.1 each time.	Small prompt from coaches/gymnasts/others 0.3 max 1.0
Two feet outside of floor area 0.3 each time.	Large prompt from coaches/gymnasts/others 0.5 max 1.0
Pauses 0.1 each time.	
DEDUCTIONS taken at the end of the routine.	
Poor posture throughout the routine. 0.1 or 0.3	Missing tumble run 0.5
Missing move: 0.3 per move less than 10 performed.	Deviation from a straight line in tumble run 0.1
Team competing out of order 1.0	Tumble run not performed on the diagonal 0.1
Two somersaults in the same direction 0.5	Tumble run not dynamic or it does not accelerate 0.1
SEE ALSO GENERAL COMPETITION DEDUCTIONS 2.1 on page 3	

7.8 EVALUATION OF MARKS

Content.	3.0
Execution.	3.5
Composition.	2.5
Bonus: 2 x Intermediate move (0.3 each).	0.6
Bonus: 1 x Advanced move.	<u>0.4</u>
TOTAL	10.0

7.9 COMPOSITION

To gain full composition marks the gymnast needs to demonstrate good use of the floor, different levels, a variety of moves, links, dance, leaps or jumps, turns, balance, strength, flexibility, dynamic moves, interesting pathways, use of forwards, backwards and sideways movements, originality, musical interpretation, the routine should be synchronised with the music and the gymnast should engage with the judges and the audience.

Marks for composition will be allocated as follows:

Use of the floor & different levels.	0.4
Variety of moves.	0.2
Links and dance.	0.6
Strength/flexibility/balance moves.	0.3
Patterns and pathways.	0.3
Musical interpretation.	0.3
Originality, dynamics, overall impression.	0.4
TOTAL	2.5

NOTES FOR COACHES AND JUDGES FOR VOLUNTARY FLOOR

- 1 All rolls must start and finish on two feet to count in the tariff.
- 2 Balances should be held for 3 seconds except for handstand which needs to be held for 2 seconds.
- 3 **As front supports are linked to either a jump to squat straight jump, a backward roll or a back support, it is only required to be held for 2 seconds.**
- 4 **In the front support to back support a straight arm must be shown high in the air in the side position of the turn This move may also be performed from back to front support. It need only be held for 2 seconds in each support position.**
- 5 Static moves like bridges, splits, pike fold and japana must be held for 3 seconds.
- 6 Splits two ways need to be held for 2 seconds each way. Splits three ways needs to be held for 1 second each way.
- 7 Flics may be landed on either one or two feet, but must land on feet and not on other body parts.
- 8 Flic with a different exit to feet when attached as a second flic is an Advanced move but counts as 2 moves towards the Content.
- 9 **Headstands:** Leg position and exit are optional but must not roll out. Deduct 0.5 for rolling out.
- 10 **Backward roll to handstand:** A backward roll passing through handstand will be counted as a backward roll which is an Elementary move. A backward roll to handstand held 1 second is an Intermediate move and a strength element. A backward roll to handstand held 2 seconds is an Advanced move and a strength and balance element.
- 11 **Somersaults:** Only one forward and one backward somersault may be used in a floor routine. The shape of the somersault is optional. **Deduct 0.5 for two somersaults in the same direction.**
- 12 Any jumps and leaps which are not in the above code will be classed as links and therefore not count in the Content.

ELEMENTARY	INTERMEDIATE	ADVANCED
Forward roll		
Forward roll to straddle stand	Forward roll to stand with straight legs together (i.e. pike)	
Backward roll	Backward roll to handstand held 1 sec	Backward roll to handstand held 2 secs
Backward roll to straddle stand	Backward roll to straight legs together (i.e. pike)	Backward roll to handstand 180° pirouette step down exit
Backward roll to front support 2 secs	Backward roll to front support 2 secs, with straight arms	Any back somersault (shape optional)
Front support 3 secs, jump to crouch – straight upward jump	Headstand with straight legs. Pike levered up to vertical – 3 secs. Exit optional but must not roll out	Any front somersault (shape optional)
Headstand 3 secs. Legs and exit optional but must not roll out	Headstand push to handstand with straight legs. Exit optional	Headstand push to handstand with straight legs. Headstand held for 3 secs or handstand held for 2 secs
Handstand 2 secs	Handstand 180° pirouette. Optional hand moves and leg positions	Handstand 360° pirouette. Optional hand moves and leg positions
Handstand forward roll	Handstand 180° pirouette then handstand held 2 secs	Handstand 360° pirouette then handstand held 2 secs
Cartwheel – to finish sideways	Handspring to step out	Handspring to 2 feet
Cartwheel ¼ turn inwards to lunge. Front knee bent (135 degrees), back leg straight.	From straddle stand press to handstand (elephant lift)	Flic with a different exit to feet when attached as a second flic, (i.e. flic to two feet, flic to walk out). Counts as 2 moves
Cartwheel ¼ turn inwards to finish feet together	Flic to land two feet together	Aerial Cartwheel
One-handed cartwheel – optional hand	Flic to 'walkout' i.e. landing first on one foot before the other	One-handed walkover (forward or backward)
Dive cartwheel		Aerial walkover
Round off	Tinsica	Flyspring
Press up in front support x 1	Backward walkover	Valdez
Teddy bear roll (Circle roll) 180° only	Forward walkover	540° spin (1 ½)
Pike fold sitting 3 secs	360° spin on one foot	720° spin (double)
Splits 3 secs	Show splits two ways, 2 secs each way	Show splits all three ways, 1 sec each
Supported shoulder stand 3 secs	Unsupported shoulder stand, arms by hips 3 secs	Unsupported shoulder stand, arms above head 3 secs
V' sit with support 3 secs	'V' sit without support (free) – 3 secs	Russian lever piked or straddled 3 secs
Japana 3 secs	Straddle lever balance 3 secs	Straddle lever balance held 3 secs then 180° turn
Back support 2 secs turn to front support 2 secs. See notes 4 below.	Pike lever balance 3 secs	Straddle lever press to handstand - optional exit
Arabesque balance 3 secs body position optional	Tuck balance 3 secs	Straddle balance press to handstand. Straddle held 3 secs or handstand 2 secs
Chair balance 3 secs	"Y" balance 3 secs	
Bridge 3 sec	'W' jump	'W' jump with 180° turn
Star jump	Tuck jump with 180° turn	Tuck jump with 360° turn
Tuck jump	Split leap	Change leg split leap
Split jump	Catleap with 360° turn	Catleap with 540° turn (1 ½)
Catleap with no turn, or 180° turn	Straddle jump	Ring leap
Stag leap or jump	Side straddle leap	Straddle jump with 180° turn
Straight jump with 180° turn	Straight jump with 360° turn	Straight jump with 540° turn (1 ½)

10 BALANCE, STRENGTH AND FLEXIBILITY ELEMENTS FOR IAPS. 5 PIECE

For use when constructing voluntary floors and group routines. Composition marks are gained by including a strength, a balance and a flexibility move as part of the 10 moves. The chart below is designed to guide you as to which moves are acceptable.

BALANCE	STRENGTH	FLEXIBILITY
Supported shoulder stand 3 secs	Backward roll to front support 2 secs	Forward roll with straight legs together (i.e. pike)
Chair balance 3 secs	Backward roll to handstand held 1 sec	Backward roll to straight legs together (i.e. pike)
Handstand 2 secs	Backward roll to handstand 180° pirouette step down exit	Japana 3 secs
Arabesque balance 3 secs. Body position optional	Handstand 180° or 360° pirouette. Optional hand moves and leg positions	Any walkovers
	Press up in front support x 1	Valdez
Headstand 3 secs. Legs and exit optional but must not roll out.	Headstand push to handstand with straight legs. Exit optional	
	Front support 2 secs turn to back support 2 secs (or vice versa). See notes page 14	Pike fold sitting 3 secs
	Straddle stand press to handstand	Tinsica
		Bridge 3 secs
		Split leap showing 180° split
		Straddle jump legs parallel to floor
THE MOVES BELOW SERVE TWO REQUIREMENTS		
Splits 3 secs		Splits 3 secs
'Y' balance 3 secs		'Y' balance 3 secs
Unsupported shoulder stand 3 secs	Unsupported shoulder stand 3 secs	
Free 'V' sit – unsupported 3 secs	Free 'V' sit – unsupported 3 secs	
Tuck balance 3 secs	Tuck balance 3 secs	
Pike lever balance 3 secs	Pike lever balance 3 secs	
Straddle lever balance 3 secs	Straddle lever balance 3 secs	
Russian lever balance either piked or straddled 3 secs	Russian lever balance either piked or straddled 3 secs	
Headstand push to handstand with straight legs. Headstand held for 3 secs or handstand held for 2 secs	Headstand push to handstand with straight legs. Headstand held for 3 secs or handstand held for 2 secs	
Headstand pike levered up to vertical with straight legs held for 3 secs.	Headstand pike levered up to vertical with straight legs held for 3 secs.	
Backward roll to handstand held 2 secs	Backward roll to handstand held 2 secs	
Handstand 180° or 360° pirouette then handstand held 2 secs	Handstand 180° or 360° pirouette then handstand held 2 secs	
Straddle lever balance press to handstand (optional exit) . Either hold the straddle balance for 3 secs or the handstand for 2 secs	Straddle lever balance press to handstand optional exit	Straddle lever balance press to handstand optional exit (moving through japana)

One move may count to serve two requirements. i.e. performing splits held for 3 seconds will count as both a balance and a flexible move. Performing a straddle lever balance held for 3 seconds will count as both a balance and a strength move worth 0.2 (0.1 each).

Straddle lever balance press to handstand with an optional exit actually **fulfils all three requirements.** However for this competition **it may only count for two of the three requirements** and therefore a second move would be required to gain the full 0.3 for strength/flexibility/balance in the composition marks. See composition allocation for the Voluntary Floor No. 7.9 on page 14.